



Exploring the Impact of Motivation on Language Learning and Student Engagement

Carlo Vinci L. Arcipe^{a*} and Jerlyn G. Balones^a

^a Faculty of the Professional Schools, University of Mindanao, Matina, Davao City, Philippines.

Authors' contributions

This work was carried out in collaboration between both authors. Both authors read and approved the final manuscript.

Article Information

DOI: 10.9734/AJESS/2023/v46i31002

Open Peer Review History:

This journal follows the Advanced Open Peer Review policy. Identity of the Reviewers, Editor(s) and additional Reviewers, peer review comments, different versions of the manuscript, comments of the editors, etc are available here: <https://www.sdiarticle5.com/review-history/101606>

Original Research Article

Received: 08/05/2023

Accepted: 15/06/2023

Published: 06/07/2023

ABSTRACT

Numerous studies have linked language learning problems to student motivation and engagement. This study examines the interceding effect of Motivation to Learn on students' Speaking, Reading, Listening, and Writing difficulties and their Affective, Cognitive, and Behavioral Engagement. The tools used for data collection were Adapted Standardized Questionnaires implemented through an e-Survey using Google Forms. This study utilized a descriptive-correlational design with 359 Grade 11 and 12 students enrolled in the 2nd Semester, 2021–2022 at 3 private institutions in Davao City, selected through Stratified Sampling. Mean, Pearson r, Regression Analysis and Path Analysis were employed as the data analysis tool. The study revealed that (1) Students sometimes experience language learning problems ($\bar{x}=2.40$, $SD=0.53$) (2) Students sometimes experience positive events inside the campus ($\bar{x}=3.41$, $SD=0.81$) (3) Students are sometimes motivated to carry on learning the English Language ($\bar{x}=3.11$, $SD=0.92$). Furthermore, it was found that Language Learning Problems and Student Engagement are positively and significantly correlated ($r=0.135$, $p=0.010$), Language Learning Problems and Motivation to Learn is negatively and insignificantly correlated ($r=-0.060$, $p=0.255$), and Motivation to Learn and Student Engagement is

*Corresponding author: Email: carlovinciarcipe@umindanao.edu.ph

positively and significantly correlated ($r=0.579$, $p<0.001$). The study also revealed that Motivation to Learn has partially interceded the relationship between Language Learning Problems and Student Engagement ($\beta=.26$, $p<.005$).

Keywords: Education; language learning problems; motivation to learn; student engagement; mediating effect.

1. INTRODUCTION

Student engagement in English classes has been a concern for many educators and researchers in the past few years. One of the main problems regarding student engagement in an English class is the lack of motivation. Zou [1] discussed that many students are never motivated to learn the language, and as a result, they tend to be less engaged in the class and in the learning process. Getie [2] added that this can be due to a variety of reasons, such as the lack of relevance of the subject matter, a negative classroom environment, or a lack of interest in the language. Several authors added other reasons as to why student engagement has been deteriorating over the past few years. One of them is that the use of traditional teaching methods that may hardly be effective for all students. Wang [3] discussed that some students may find the teaching methods used in English classes to be boring or unengaging, and as a result, they may not be motivated to participate in class discussions and activities.

Moreover, Sari [4] added that students may also experience problems in language learning that can affect their engagement in the class. Lastly, Simamora [5] technological advancements have changed the way students learn and interact with information, and some students may find it challenging to engage with traditional classroom learning environments. All these notions are aligned with both Locke and Latham's [6] Goal Setting Theory, and Vygotsky's Collaborative and Social Learning Theory found on the work of Gopinathan [7]. Locke and Latham's Goal Setting Theory [6] emphasizes the importance of setting challenging and specific goals in motivating people to achieve more. This concept suggests that, in the context of student participation in English classes, educators can increase student motivation by establishing clear goals and objectives for English learning. Setting specific, challenging, yet attainable goals may inspire students to work harder and become more engaged in English classes.

Vygotsky's Collaborative and Social Learning Theory found on the work of Gopinathan [7], on

the other hand, emphasizes the importance of social contact and collaboration in the learning process. This concept suggests that by fostering a collaborative and supportive learning environment, teachers can increase students' motivation in the context of English class engagement. Students can learn from one another and become more invested in the learning process by encouraging peer-to-peer interactions, group discussions, and cooperative learning activities. These theories contend that increasing student engagement in English classes necessitates both individual and group goal setting. By establishing clear learning goals and objectives and fostering a supportive, collaborative learning environment, instructors can encourage students to participate more in English lessons.

The study of affective, behavioral, and cognitive engagement is important for understanding student motivation, involvement, and learning outcomes in the classroom. These three dimensions of engagement are interrelated and can impact a student's overall experience in the classroom. Dincer [8] have shown that students who are more engaged in their learning, whether through affective, behavioral, or cognitive engagement, tend to have better academic outcomes, including higher grades, increased knowledge retention, and improved critical thinking skills. On the other hand, students who are less engaged tend to experience lower grades, reduced motivation, and a decline in overall learning.

A study conducted by Xu, Chen, and Chen [9] in 2020 have also revealed that affective, behavioral, and cognitive engagement are interrelated, and that when one dimension of engagement is improved, it can lead to positive changes in the other two dimensions. For example, a study by She et al. [10] found that when students have positive attitudes towards learning, they are more likely to engage in behaviors that support learning, such as asking questions or participating in class discussions. In turn, these behaviors can lead to increased cognitive engagement, as students become more focused on the learning process.

From the Philippines's landscape, in terms of the impact of motivation to learn on language learning problems, Torres and Alieto [11] found that students who were more motivated to learn English had better language learning outcomes compared to students who were less motivated. The study found that motivation was positively related to language learning outcomes, such as increased vocabulary knowledge and improved grammar skills. In terms of the role of engagement in second language acquisition, Dizon et al. [12] found that students who were more engaged in the classroom, through behaviors such as participation in class discussions, completing homework, and attending classes regularly, had better language learning outcomes compared to students who were less engaged. The study also found that students who were more engaged in the learning process were more motivated to learn the language.

Despite the plethora of data on Language Learning Problems, Student Engagement, and Motivation to Learn, there is still the need for further research to fully understand the relationship between these variables and language learning outcomes. By exploring the importance of student engagement and motivation in language learning in greater depth, educators in the Philippines can develop more effective strategies this study to support student success in language learning. More specifically, given the following facts, we may deduce the motivation of the researcher to conduct this study: if a drop in Language Learning Problem results in an increase in Motivation to Learn, which results in an increase in Student Engagement. Additionally, this study aims to determine if an increase in student engagement can assist learners in overcoming their Language Learning Problems.

Atmojo and Nugroho [13] discussed that language learning can be a challenging task for students, and it is often difficult to maintain engagement in the classroom. One of the main problems in language learning is the lack of opportunities for students to practice using the language in real-life situations. Esra and Sevilen [14] supported this claim and added that this can lead to a lack of motivation and interest in the subject, as students may feel that what they are learning is not relevant to their daily lives.

Another problem that can affect student engagement in language classes is the lack of

personalization in instruction [15]. Many language classes are taught in a one-size-fits-all approach, which can be frustrating for students who have different learning styles or who are at different levels of proficiency. Additionally, language classes can also be affected by cultural barriers. Fitriyani and Andrivanti [16] added that any students may feel uncomfortable or out of place in a language class if they do not feel like their culture is represented or respected. This can lead to students feeling disengaged and uninterested in the subject matter.

On the other hand, Esra and Sevilen [14] also discussed that when students are engaged in their English classes, they are more likely to experience fewer problems in language learning. Engaged students are motivated to learn and are invested in their education, which can lead to a more positive and successful learning experience. One of the main benefits of higher engagement in English classes is an increase in motivation. Mercer elucidated that students who are engaged in their classes are more likely to put in the effort to learn and practice the language [17].

This can lead to a greater sense of accomplishment and a higher level of confidence in using the language. Furthermore, the researcher also added that engaged students tend to be more invested in learning the language and are more likely to seek out opportunities to practice and improve their skills. Another benefit of higher engagement in English classes is an increase in interest in the subject matter. Zaidi [18] discussed that when students are engaged in their classes, they tend to be more curious about the language and are more likely to be interested in learning about different cultures and customs. This can lead to a more well-rounded understanding of the language and can make the learning experience more enjoyable.

Motivation is a key factor in language learning, and the more motivated students are to learn the language, the less they will experience problems with it. Lou, Mantou, and Noels elucidated that when students are motivated to learn, they are more likely to put in the effort to acquire the language, which can lead to a more positive and successful learning experience [19].

One of the main benefits of motivation in language learning is an increase in effort and practice. When students are motivated to learn,

they are more likely to put in the effort to study, practice, and use the language [20]. This can lead to a greater sense of accomplishment and a higher level of confidence in using the language. Furthermore, Mercer added that motivated students tend to be more invested in learning the language and are more likely to seek out opportunities to practice and improve their skills [17].

Another benefit of motivation in language learning, according to Lee, Ho, and Chen [21] is an increase in interest in the subject matter. When students are motivated to learn, they tend to be more curious about the language and are more likely to be interested in learning about different cultures and customs. Chi, Chen, Tseng, and Liu. agreed with this notion and added that this can lead to a more well-rounded understanding of the language and can make the learning experience more enjoyable [22].

On the other hand, demotivation can be a major obstacle to language learning. Alyousif and Alsuhaibani [23] agreed with this notion and added that the more demotivated students are when learning the language, the more problems they will experience. Wallace and Leong added that when students are demotivated, they are less likely to put in the effort to acquire the language, which can lead to a negative and unsuccessful learning experience [3].

One of the main problems associated with demotivation in language learning is a lack of effort and practice. When students are demotivated, based on the work of Evans and Tragant [24], they are less likely to study, practice, and use the language, which can lead to a lower level of proficiency and a lack of confidence in using the language. Furthermore, Tran and Moskovsky [25] added that demotivated students tend to be less invested in learning the language and are less likely to seek out opportunities to practice and improve their skills. Another problem associated with demotivation in language learning is a lack of interest in the subject matter. Putri, Suyarno, and Hardiyanto [26] added that when students are demotivated, they tend to be less curious about the language and are less likely to be interested in learning about different cultures and customs which can lead to a narrow and superficial understanding of the language and can make the learning experience unenjoyable.

As students' motivation to learn the language increases, so does their class engagement. Esra

and Sevilen [14] agreed with this notion and added that Motivation is a crucial factor in language learning, and when students are motivated to learn, they tend to be more engaged in the class and in the learning process. One of the main ways in which motivation affects class engagement is through an increase in effort and practice. When students are motivated to learn, they are more likely to put in the effort to study, practice, and use the language [20].

They added that this can lead to a greater sense of accomplishment and a higher level of confidence in using the language, which in turn can increase engagement in the class. Furthermore, Mercer added that motivated students tend to be more invested in learning the language and are more likely to seek out opportunities to practice and improve their skills, which can lead to a more positive and successful learning experience [17].

Another way in which motivation affects class engagement is through an increase in interest in the subject matter. When students are motivated to learn, they tend to be more curious about the language and are more likely to be interested in learning about different cultures and customs [21]. Nagle's ide correlates with the previous statement, elucidating that this can lead to a more well-rounded understanding of the language and can make the learning experience more enjoyable, which as a result, enables students to be more inclined to pay attention and participate in class discussions and activities [27].

On the other hand, there are some instances that as students' motivation to learn the language decreases, so does their class engagement. Alamer and Almulhim's [28] work is in congruence with this notion, discussing that motivation is a crucial factor in language learning, and when students are not motivated to learn, they tend to be less engaged in the class and in the learning process. One of the main ways in which a decrease in motivation affects class engagement is through a lack of effort and practice. Lestari and Wahyudin [29] discussed that when students are not motivated to learn, they tend to be less likely to put in the effort to study, practice, and use the language. This can lead to a lower level of proficiency and a lack of confidence in using the language, which in turn can decrease engagement in the class. Furthermore, Philippakos added that demotivated students tend to be less invested in

learning the language and are less likely to seek out opportunities to practice and improve their skills, which can lead to a negative and unsuccessful learning experience [30].

Another way, according to Anwer [31], in which a decrease in motivation affects class engagement is through a lack of interest in the subject matter. Lambert and Zhang added that when students are not motivated to learn, they tend to be less curious about the language and are less likely to be interested in learning about different cultures and customs [32], which can lead to a narrow and superficial understanding of the language and can make the learning experience unenjoyable. As a result, students are less inclined to pay attention and participate in class discussions and activities.

Several theories have surfaced and have been able to support and enhance language learning, motivation, and engagement. We begin discussing the anchor theory that would bind all the theories and variables mentioned in this study which would be Gardner's Socio-educational Model [2]. This indicates the motivation of the student in learning a language. The model is connected to two ideas: either the student wants to learn the language for communication purposes (*integrative motivation*), or the student wants to learn the language so he/she could use it for educational or work purposes (*instrumental motivation*). In the context of this study, given that the students are to be engaged in learning the language, their motivation in doing so must be aligned with their purpose; setting a specific and challenging goal to increase motivation.

Furthermore, applying these ideas in the context of this study; since learning the language can either be instrumental or integrative, we can further deduce that a learner could choose which one would be the path they are to concentrate on. This would allow the learners to concentrate and be ascertained to learn the language without any external influences and autonomy that would lead to them overcome their language learning problems; given the fact that they can monitor their language usage. The learners can do this since they purposefully do the things that allow them to surmount their language learning problems, given their engagement with learning the language in the first place.

Next, we combine the ideas of Language Learning Problems and Motivation to Learn

through the theory of Self-Determination by Ryan and Deci [33] where they talked about the motivation of a learner to learn the language without external influences and interference will then lead to autonomy. Applying this idea to the context of this study, if the student can overcome his/her difficulties in learning the language; then the student will be able to learn the language since the student is motivated to do so. This implies that if the motivation of the students to learn increases, their language learning problems decreases.

To support the notion that there is a connection between Student Engagement and Motivation to Learn is Locke and Latham's [6] Goal Setting Theory where he mentioned that students are to set their goals in learning the language so that they can keep themselves challenged and motivated. Applying this theory to the context of this study, they need to receive regular feedback on their progress and provided, the learners will then be engaged, productive, and motivated to learn more of the language presented. This implies that if the motivation of the student to learn increases, the engagement of the students in classes also increases.

The last connection to be made would be between Student Engagement and Language Learning Problems which is possible through Vygotsky's Collaborative and Social Learning Theory found on the work of Gopinathan [7] where he cited that the learning process of a learner acquiring a second language will continue to be more effective as a result of interactions, they engage in with peers that are more knowledgeable. This will also exponentially increase their affective, behavioral, and cognitive engagement, ensuring the learners' development. The implication of Vygotsky's idea in this study can be double-edged, we can deduce that students; given that they are engaged in learning the language, must have a clear goal to overcome their language learning difficulties. Specifically, learners are to be proficient in speaking, reading, writing, and listening after hitting the goals they have purposefully set. Conversely, this also means that if the students are not engaged in setting appropriate goals when it comes to learning the language, this would effectively increase their problems in learning the language. Simply put, as the language learning problems of the students increases, their engagement in learning the language decreases.

The theories presented above served as basis for the following hypothesis: the less engagement students have with their English classes, the more problems in Language Learning the students will experience; The more motivated the students are with learning the language, the less they will experience problems with learning the language; and as students' motivation to learn the language increases, so does with their class engagement.

Campbell and McMartin as the ability to interpret written information, where one may have access to a wide range of resources. Listening Skills, according to Sabdarifah, is "the ability of one individual to perceive another via sense, auditory organs, give a meaning to the message and grasp it." Lastly, Writing Skills is the encoding of letters and characters on various materials, such as paper and wood, for the purpose of capturing thoughts (Anderson, Sandberg, and Garpelin).

The mentioned theories also served as the primary bases for the conceptual design of the study presented in Fig.1.

The dependent variable would be Student Engagement in terms of Affective, Cognitive, and Behavioral aspects. Saeki defined this as how a learner is meaningfully engaged in the learning activity through different affective, behavioral, and cognitive engagements, ensuring the learners' development, especially in learning the language. This has three main indicators: Affective, Behavioral, and Cognitive. Affective engagement is defined by Furlong et al. as the positive emotions that people experience when participating in activities. On the other hand, Behavioral Engagement is defined by Finn and Rock as placing a high value on proper conduct, such as abiding by rules and not causing trouble. Lastly, Cognitive Engagement is defined by Fredricks et al. as are the desire to go above and beyond what is expected at school, or a preference for taking on new and difficult tasks.

Shown in Fig. 1 is the conceptual paradigm that indicates the three variables of this study. The independent variable would determine the language learning problems or issues that students encounter when learning English, specifically in terms of Speaking, Reading, Writing, and Listening Skills. This is influenced by the study of Pawapatcharandom where she defined Language Learning Problems as "the issues that students encounter when learning the English Language". Al-Garni and Almuhammid defined Speaking Skills as "the act of constructing and communicating meaning via the use of verbal or non-verbal symbols, across many situations". Reading skills is defined by

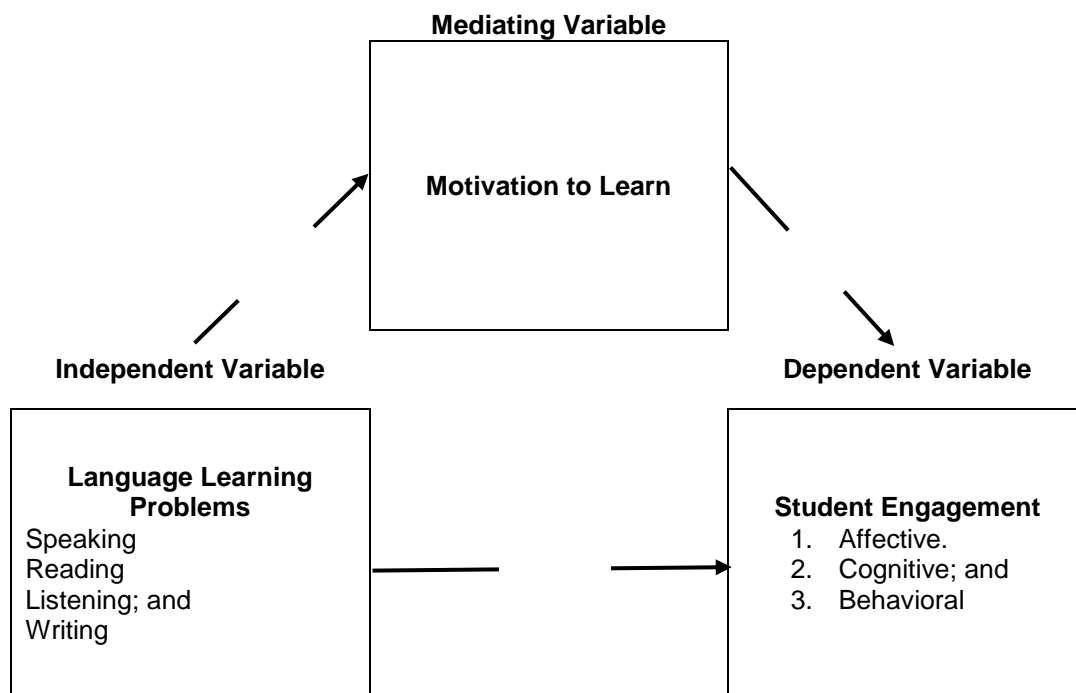

Fig. 1. Conceptual framework of the study

These ideas would be correlated to the Motivation to Learn of the students. Amirian and Komesh defined this as a motivating power in any situation that leads to action. Ryan and Deci [33] colluded with this idea, defining Motivation to Learn as the "the motivation to engage in an activity for its own sake, without any external rewards or punishments." They further state that motivation to learn is associated with a number of positive outcomes, such as increased learning, creativity, and well-being. Pintrich added that Motivation to Learn is "the set of beliefs, values, and emotions that influence how people approach learning tasks." He further states that motivation to learn is a complex construct that is influenced by a variety of factors, including the individual's goals, beliefs about their ability, and the perceived value of the task.

Numerous research has established a link between the effect of language learning problems on student engagement. However, little emphasis has been paid to the specific areas of learning in which learners struggle, namely Speaking, Listening, Reading, and Writing. They only point out general discussions on how to tackle issues in relation to their language learning problems. Additionally, a small number of research have been conducted to examine the relationship between Language Learning Problems and Student Engagement, especially Cognitive, Affective, and Behavioral Engagement. Finally, because the combination of these variables have not been explored specifically for the population specified in this study, it is uncertain if they have a substantial effect on the Second Language Learning of the group selected for this study.

This study aims primarily at examining the interceding effect of Motivation to Learn on the relationship between the difficulties that the Grade 11 and Grade 12 senior high school students encounter when it comes to Speaking, Reading, Listening, and Writing, the their level of Affective, Cognitive, and Behavioral Engagement, as well as the level of their Motivation to Learn. Specifically, the study will work to realize to: First, determine the level of Language Learning Problems in terms of Listening, Speaking, Reading, and Writing Skills; Second, determine the level of Student Engagement in terms of Affective, Behavioral, and Cognitive Engagement; Third, Idetermine the level of Motivation to Learn. Fourth, determine the significant relationship between (a) Language Learning Problems and Student Engagement, (b)

Language Learning Problems and Motivation to Learn; and (c) Motivation to Learn and Student Engagement. Lastly, this study aims to determine the interceding effect of motivation to learn on the relationship between language learning problems and student engagement

It is geared towards discerning the interceding effect of motivation to learn on the relationship between language learning problems and student engagement of the Senior High School Students. Further, the findings of the study may hopefully benefit the following:

First, this would benefit the global community of researchers since this study would add to the repository of knowledge related to motivation to learn (learning motivation), language learning problems, and student engagement, derived from the data, results, conclusions, and recommendations from this study which will serve as the stepping-stone for the future researchers.

Second, this will benefit the community, especially the parents when it comes to assisting their children in dealing with their language learning problems and on approaching the student's motivation to learn and student engagement. Lastly, this will benefit the Institution since the result of the study may give significant information about the different Language Learning Difficulties that students encounter; The instructors since the result of the study may serve as their guide in deciding how to effectively address the different language learning difficulties and enhance student engagement of the learners; and the Future Researchers since the information provided in this study may be used to supplement their future studies.

2. METHODS

2.1 Research Respondents

The respondents selected were Grade 11 and 12 Senior High School online learning students from 3 Academic Institutions at Davao City, the names of which were redacted, who were enrolled in the 2nd Semester, Academic Year 2021 – 2022 using the Yamane's Simplified formula of proportions with 5% margin of error. Particularly from students of the following Academic Strands: Science, Technology, Engineering, and Mathematics (STEM), Accountancy, Business, and Management (ABM), Humanities and Social

Sciences (HUMSS), and General Academic Strand (GAS) who were enrolled in Oral Communication and English for Academic and Professional Purposes from the 1st Semester and in Reading and Writing in the 2nd Semester. The total number of respondents for this study were 359 Grade 11 and 12 Senior High School Online Learning students who were enrolled in 2nd Semester, academic year 2021 – 2022 at 3 private academic institutions in Davao City.

Following the Stratified Random Sampling method (Easton & McColl) where the stratified sample is obtained by taking samples from each stratum or sub-group of a population, the researcher was able to compute for the representation of each grade which provided them with the samples needed per grade from each institution: School A had the following population per grade: 808 Grade 11 and 1186 Grade 12 Students. This brought the samples needed per grade of School A: 84 Grade 11 and 124 Grade 12 Students. School B had the following population per grade: 155 Grades 11 and 76 Grade 12 Students. This brought the samples needed per grade of School B: 16 Grade 11 and 8 Grade 12 Students. School C had the following population per grade: 400 Grades 11 and 804 Grade 12 Students. This brought the samples needed per grade of School C: 42 Grade 11 and 84 Grade 12 Students.

Since the data was gathered online, the study excluded students with printed modular as their chosen mode of learning for the 2nd Semester of A.Y. 2021-2022 due to their lack of access to the internet or to any gadgets. Second, this study excluded Grade 11 and Grade 12 students from the Technical, Vocational, and Livelihood (TVL) Track since even though they have subjects and activities that require the use of the English Language, their focus is more on pragmatic and applied activities that require skills and knowledge of their chosen specializations (Hospitality, Tourism, Industrial Arts, Cookery, etc.). Lastly, this study excluded participants who were not bona fide, who either have dropped or totally withdrawn, or who had transferred to other academic institutions beyond the scope of the study as this would have set off issues that might arise when contacting the participants and when collecting data.

A participant has the right to refuse to take part if they did not feel comfortable. A participant could leave the research study at any time. Upon withdrawing from the study, the participant would

have informed the researcher that they wish to withdraw. A participant may provide the researcher with reason(s) for leaving the study but is not required to provide their reason. If they chose to withdraw from the study, all their information as well as the data collected from them were immediately discarded and were neither be retained nor included in the interpretation and publishing of the final paper in accordance with Republic Act 10173 or the Data Privacy Act of 2012.

They were chosen as respondents because most of the activities to be held in these classes include a combination of the 4 macro-skills which they can use upon moving forward to their higher years. They were also selected due to the poorer student engagement of the students in class documented through in-class observations, as well as recorded exams, quizzes, and participations.

2.2 Materials and Instrument

The instrument used in the study consists of four parts. Part 1 questionnaire dealt with the Demographic Data that focused on the age, gender, and their year level. Part 2 focused on the Language Learning Difficulties of the Senior High School Students. Part 3 focused on the Student Engagement of the Senior High School Students. Part 4 focused on the Language Learning Motivation of the Senior High School Students.

These questionnaires were patterned, adapted, and modified from the research conducted by Elina Saeki [4] on *Student Engagement and Motivation: An Evaluation of Their Relations to Social-Emotional and Behavioral Functioning*; Ratana Pawapatcharandom [34] on *An Investigation of Thai Students' English Language Problems and their Learning Strategies in the International Program at Mahidol University*, and from the work of Seyyed Mohammad Reza Amirian and Najme Komeshe's [10] on *A Study on the Relationship between EFL Learners' Nationality and Language Learning Motivation*.

Before performing the Cronbach's α to determine the reliability of the questionnaire, the adapted questionnaires were submitted for validation by five expert validators, three of which were from the University of Mindanao and two of which were from external sources. Upon validation, it yielded a total validation rating of 4.484, which means that based on the check made by the

internal and external evaluators, the questionnaire was structurally cohesive, and its purpose was aligned on the research objectives, making it suitable for implementation.

Following the Part 1 of the Questionnaire (Demographic Data), the second part was adapted from Ratana Pawapatcharaudom's [34] *An Investigation of Thai Students' English Language Problems and their Learning Strategies in the International Program at Mahidol University*. This instrument used a five-point Likert scale that measured how often students experience Language Learning Problems. It was divided into four subsections: speaking, listening, reading, and writing. The questionnaire was verified by Dr. Ngamthip Wimolkasem, a professor at King Mongkut's Institute of Technology North Bangkok. In addition, the study of Abe et al. tested the reliability of the instrument using Cronbach's α yielding the result of 0.843 which meant that the instrument is reliable [34]. On the context of the study, after performing a pilot testing, this section yielded a Cronbach's α based on Standardized Items value of 0.968, implying further that the questionnaire is reliable.

The third part of the Questionnaire was from the research conducted by Elina Saeki [4] on her *Student Engagement and Motivation: An Evaluation of Their Relations to Social-Emotional and Behavioral Functioning*. This instrument used a five-point Likert scale that measured student's feelings about school in relation to their engagement. It is divided into three subsections: Affective, Behavioral, and Cognitive Engagement. Individually, Saeki tested the reliability of each section and yielded the following results:

First, Affective Engagement section reported a Cronbach's α of .87, Second, Behavioral Engagement section reported a Cronbach's α coefficient of .84, and Lastly, Cognitive Engagement section reported a Cronbach's α of .87, implying that the questionnaire was reliable. On the context of the study, after performing a pilot testing, this section yielded a Cronbach's α based on Standardized Items value of 0.959, implying further that the questionnaire is reliable.

Lastly, the Part 4 of this Questionnaire was from Seyyed Mohammad Reza Amirian and Najme Komesh's [10] *A Study on the Relationship between EFL Learners' Nationality and Language Learning Motivation*. Amirian and

Komesh tested the reliability of this Questionnaire between three different nationalities, in respect to their study, and it yielded the following results: First, Cronbach's α test with Persians reported a reliability score of 0.801; Second, Cronbach's α test with Turks reported a reliability score of 0.752; and Lastly, Cronbach's α test with Arabs reported a reliability score of 0.794, further implying that this questionnaire was reliable. On the context of the study, after performing a pilot testing, this section yielded a Cronbach's α based on Standardized Items value of 0.963, implying further that the questionnaire is reliable.

To interpret the participants' responses to the Motivation to Learn, Language Learning Problems, and Student Engagement questionnaires, the following rating scale was utilized: From 4.20 to 5, this is described as *Very High*, implying that Measures of Motivation to Learn, Language Learning Problems, and Student Engagement are always manifested and/or observed. From 3.40 to 4.19, this is described as *High*, implying that Measures of Motivation to Learn, Language Learning Problems, and Student Engagement are often manifested and/or observed. From 2.60 to 3.39, this is described as *Moderate*, implying that Measures of Motivation to Learn, Language Learning Problems, and Student Engagement are sometimes manifested and/or observed. From 1.80 to 2.59, this is described as *Low*, implying that Measures of Motivation to Learn, Language Learning Problems, and Student Engagement are seldom manifested and/or observed. From 1.00 to 1.79, this is described as *Very Low*, implying that Measures of Motivation to Learn, Language Learning Problems, and Student Engagement are never manifested and/or observed.

The research questionnaire was submitted to the research adviser for comments and suggestions. Upon approval, the instruments were validated by the experts and the University of Mindanao Ethics Review Committee before deploying the survey.

2.3 Design and Procedure

The study made use of Creswell's Descriptive – correlational design to help provide specific direction for procedures in this research study. This study made use of descriptive design to determine, describe and analyze the level of the three variables which are the motivation to learn,

the language learning problems of Grade 11 and 12 Senior High School students, and their engagement. This study also made use of the correlational design to describe and measure the degree or association (or relationship) between two or more variables or sets of scores (Asenahabi), particularly in determining the interceding effect of motivation to learn on the relationship between language learning problems and student engagement.

The study duration was estimated to be around four to twelve weeks; during the first four weeks in the study's implementation, the researcher requested a signatory for the letter to conduct the study from the University of Mindanao Professional Schools and complied the necessary requirements to acquire the Ethics Review Certification from the University of Mindanao Ethics Review Committee. Upon approval, the researcher then coordinated with the Principal, the Senior High School Registrar, and the class advisers of the three academic institutions and asked assistance for the students to participate in answering the survey questionnaires.

Before the study's implementation, the researcher together with the help of the assigned Guidance Counselor of each Academic Institution clearly explained to the participants the study's details, its benefits, and how this was done through a Virtual Briefing and Debriefing. For minor respondents, they were asked to read and fill out an Assent Form and their Parent or Legal Guardian were also asked to fill out a Parent's Consent Form allowing them to participate in the study. Once agreed, the researcher started the data gathering. For the fifth until the final week, the researcher compiled the data from the Digital Version of the Adapted Research Questionnaire filled out by the respondents and were analyzed and evaluated by the University's Assigned Statistician in accordance with their importance based on the study's hypothesis and objectives.

Upon the conclusion of the study, the data collected from the respondents, which has been retained in accordance with the Data Privacy Act of 2012, was expunged properly to avoid unnecessary access to the sensitive data of the study.

Following the specification of the Statistical Tools when analyzing data, the researcher utilized Mean to determine the level of Language

Learning Difficulties, Student Engagement, and Language Learning Motivation of the Grade 11 and 12 Senior High School Students, Pearson's r to determine the correlation of the student's Language Learning Problems and Student Engagement; student's Language Learning Problems and Motivation to Learn; and Motivation to Learn and Student Engagement of the Grade 11 and 12 Senior High School Students, Regression Analysis to determine the relationship between and among the variables, and Path Analysis to understand the interceding effect of Motivation to Learn on the relationship between Language Learning Problems and Student Engagement.

In terms of the ethical considerations, the following were regard before, during, and after data gathering. It relates to moral standards that the researchers should consider in all research methods in all research design stages. The researchers obtained written informed consent from all participants and their Parent or Legal Guardian to conduct a survey and utilize the allotted time to discuss the following research ethical standards: *Inclusion Criteria, Exclusion Criteria, Withdrawal Criteria, Potential Risk(s) and Benefits, Voluntary Participation, Privacy and Confidentiality, Informed Consent, Fabrication, Falsification, Deceit, Conflict of Interest, Permission from Location/Organization, Technology Issue(s), Authorship, and the Rights of the Research Participants.*

All these moral standards were discussed and stipulated on the Informed Consent Form, Child Assent Form, and Parental Consent Form which were used in conducting the study. The aforementioned forms were approved by the Ethics Review Committee on May 7, 2022 with Certification Number UMERC-2022-086.

3. RESULTS AND DISCUSSION

This section of the paper focuses on the presentation of the data collected from implementing the study. The tables presented are exhibited with the following subheadings: Level of Language Learning Problems, Level of Student Engagement, Level of Motivation to Learn, Significance on the Relationship between Language Learning Problems and Student Engagement, Significance on the Relationship between Language Learning Problems and Motivation to Learn, Significance on the Relationship between Motivation to Learn and Student Engagement, and Mediation Analysis of

the interceding effect of Motivation to Learn on the relationship between Language Learning Problems and Student Engagement

Indicated in the statistical tables, the total standard deviation of Tables 2 to 4 ranged from 0.53 to 0.92, signifying that the overall ratings per indicator garnered from the data collection of the study are consistent among all the participants (Wittink and Bayer).

3.1 Language Learning Problems

Table 1 suggests Grade 11 and 12 Senior High School students may have low language learning problems. Language learning problems occur "seldomly" for students with a mean score of 2.40. The standard deviation of 0.53, indicating moderate data variation, supports this.

In descending order, we have Writing (2.46), speaking (2.45), reading (2.35), and listening (2.34). Despite the low result, students are more likely to have language learning problems in writing than any other skill (Yusof, Zarina, & Yunisrina, Ebadi & Rahimi). Writing's complexity may explain this. Students must organize their thoughts, communicate clearly, and use proper grammar and punctuation. Writing can also be harder for L2 learners. They may be less proficient in the L2 than in their native language (Fernandez-Dobao).

Krashen's Theory of Comprehensible Input, found on Patrick [35], states that language learners learn best when exposed to input slightly above their current proficiency. This input should be understandable but challenging enough to make learners think about the language and make inferences. Table 1 shows that Grade 11 and 12 Senior High School students receive diverse language input in class. They are challenged in listening, speaking, reading, and writing. This input may aid them in language acquisition and improvement.

Comprehensible input also explains how learners "sometimes" have language learning problems. This theory states that language learning is gradual and requires effort. Language learners will struggle, however by receiving comprehensible input, they will eventually master the language.

Table 2 shows Grade 11 and 12 Senior High School Students' Level of Student Engagement. The mean score is 3.15, which is moderate, indicating that students occasionally enjoy school life. Behavioral Engagement has the highest mean score of 3.18, followed by Cognitive Engagement at 3.16 and Affective Engagement at 3.12.

Engagement improves academic performance (Naibert et al. [36]; Daily et al. [8]). Naibert et al. found that more engaged students had higher GPAs and test scores [36]. Daily et al. found that engaged students were more likely to graduate [8]. The moderate mean score for the three student engagement indicators suggests room for improvement. According to previous research, student engagement can vary depending on subject matter, teacher, and student characteristics.

3.2 Student Engagement

The Student Engagement Theory by Fredricks, Blumenfeld, and Paris, found in Mao and Lee [17], supports this result. According to the theory, student engagement has three main components: behavioral, cognitive, and emotional. Behavioral engagement is students' active participation in learning activities, cognitive engagement is their mental effort, and emotional engagement is their affective reactions to the learning environment. Table 2 shows that Behavioral Engagement is the highest indicator, followed by Cognitive Engagement and Affective Engagement. This suggests that students are actively participating in learning activities and putting mental effort into learning but may not be emotionally invested in the learning environment.

Table 1. Level of language learning problems

Indicator	SD	Mean	Descriptive Level
Writing Skills	0.64	2.46	Low
Speaking Skills	0.62	2.45	Low
Reading Skills	0.69	2.35	Low
Listening Skills	0.64	2.34	Low
Overall	0.53	2.40	Low

Table 2. Level of student engagement

Indicator	SD	Mean	Descriptive Level
Behavioral Engagement	1.02	3.18	Moderate
Cognitive Engagement	0.99	3.16	Moderate
Affective Engagement	0.96	3.12	Moderate
Overall	0.81	3.15	Moderate

3.3 Motivation to Learn

Table 3 shows the mediating variable's mean score of 3.11 and standard deviation of 0.92 for Grade 11 and 12 Senior High School Students' Motivation to Learn. Even with one low-rated item (item 15), the moderate mean for Motivation to Learn indicates that students are sometimes motivated to learn English.

There are several factor that can influence a student's motivation to learn, such as interest, self-efficacy, and perception value of the subject itself (Zhou, Sihan, and Thompson). Sari and Aminatun [37] discussed that students may want to learn English to improve their communication skills, prepare for college, or get a job. Motivation affects language learners' engagement, effort, and persistence [17]. Most students are moderately motivated to learn English based on the mean score. The highest-rated items, such as "having a great wish to learn more than the basics of English and Studying English can be vital to me because it will allow me to be more at ease with a fellow foreigner who speaks English", suggest students may have a practical or personal interest in learning English (Bashori et al. [38]). The lowest-rated item, "When I don't understand something in English class, I always ask the instructor," suggests that some students may be reluctant to ask for help or may not have a supportive learning environment. Understanding students' motivation to learn helps teachers create effective language learning strategies and interventions.

Ryan et al.'s Self-Determination Theory (SDT) [33] supports Table 3. SDT states that intrinsic motivation is most desirable form of motivation. External rewards and punishments motivate extrinsically, while personal interest and enjoyment motivate intrinsically. Students are occasionally motivated to learn English, possibly due to intrinsic and extrinsic factors. Students may learn English because they like it or realize its career benefits. Intrinsic factors are learner generated. They include enjoyment, interest, and challenge. External factors affect learners. Grades, rewards, and parental pressure (Ulfa

and Bania [39]). SDT discusses that satisfying autonomy, competence, and relatedness increases intrinsic motivation. Autonomy, competence, and relatedness in English language learning can improve students' motivation and language learning outcomes (Alamer, Abdullah, and Al Khateeb [40]).

3.4 Correlation between Language Learning Problems and Student Engagement

The Pearson correlation test showed four out of twelve significant bivariate correlations and an overall significant correlation between Language Learning Problems and Student Engagement, the independent and dependent variables respectively. In summation, Student Engagement positively and significantly correlated with Grade 11 and 12 Senior High School Language Learning Problems, $r=0.135$, $p=0.010$. First, Affective Student Engagement positively and significantly correlated with Speaking Skill Problems of Grade 11 and 12 Senior High School Students, $r=0.188$, $p<.001$. Second, Affective Student Engagement positively and significantly correlated with Grade 11 and 12 Senior High School Writing Skill Problems, $r=0.105$, $p=0.048$. Third, Behavioral Student Engagement positively and significantly correlated with Senior High School Grade 11 and 12 Writing Skill Problems, $r=0.127$, $p=0.016$. Finally, Cognitive Student Engagement positively and significantly correlated with Grade 11 and 12 Senior High School Students' Writing Skill Problems, $r=0.116$, $p=0.028$.

According to the data above, senior high school students in Grades 11 and 12 with language learning problems are more engaged. Writing and speaking skill problems were significantly related to affective, behavioral, and cognitive student engagement, respectively. Esra and Sevilen [14] found that engaged English students have fewer language learning issues, particularly in writing and speaking. Engaged students were more likely to ask questions, participate in class discussions, and finish homework. They also had more English confidence. Engaged students

learn languages faster and stick with them, according to Feng and Papi [41].

This result is also supported by Vygotsky's Collaborative and Social Learning Theory found on the work of Gopinathan [7], which emphasizes the importance of social interaction and collaboration in learning. According to Vygotsky,

students learn best when they interact with others in meaningful ways, such as collaborative writing activities, group discussions, and peer feedback. Students who are more engaged in their English classes are more likely to benefit from the social and collaborative nature of learning, which can lead to better language learning outcomes.

Table 3. Level of motivation to learn

Item	SD	Mean	Descriptive Level
Having a great wish to learn more than the basics of English.	1.36	3.31	Moderate
Studying English can be vital to me because it will allow me to be more at ease with a fellow foreigner who speaks English.	1.36	3.31	Moderate
Studying English is essential for me so that I can graduate from school.	1.38	3.31	Moderate
Studying English can be essential for me because it will allow me to meet and converse with more varied people.	1.36	3.26	Moderate
Having the desire to learn English.	1.35	3.25	Moderate
I try to understand all the English I see and hear.	1.37	3.23	Moderate
Trying to understand the more complex aspects of English.	1.35	3.22	Moderate
Thinking that learning English is fun.	1.29	3.14	Moderate
Enjoying learning English.	1.31	3.12	Moderate
Treating English as an essential part of my program.	1.29	3.07	Moderate
Doing the checking of my corrected assignments in my English course.	1.26	3.00	Moderate
Keeping up to date with English by working on it almost every day.	1.17	2.96	Moderate
Tending to approach my English homework in a planned manner.	1.13	2.85	Moderate
When studying English, I ignore distractions and stick to the job at hand.	1.08	2.77	Moderate
When I have a problem understanding something we are learning in my English class, I always ask the instructor for help.	1.11	1.89	Low
Overall	0.92	3.11	Moderate

Table 4a. Significance of the Relationship between Language Learning Problems and Student Engagement

Language Learning Problems	Student Engagement			
	Affective	Behavioral	Cognitive	Overall
Speaking Skills	.188** .000	.096 .069	.084 .111	.148** .005
Listening Skills	.098 .064	.044 .404	.024 .648	.067 .208
Reading Skills	.092 .082	.071 .181	.062 .242	.091 .085
Writing Skills	.105* .048	.127* .016	.116* .028	.141** .007
Overall	.145** .006	.102 .053	.087 .101	.135* .010

3.5 Correlation between Language Learning Problems and Motivation to Learn

Table 4b. Significance of the Relationship between Language Learning Problems and Motivation to Learn

Language Learning Problems	Motivation to Learn
Speaking Skills	-.063 .230
Listening Skills	-.090 .087
Reading Skills	-.003 .951
Writing Skills	-.045 .396
Overall	-.060 .255

The Pearson correlation test showed no significant bivariate or overall correlation between Language Learning Problems and Motivation to Learn, the independent and mediating variables respectively. Overall, Motivation to Learn negatively and insignificantly correlated with Language Learning Problems of Grade 11 and 12 Senior High School Students, $r=-0.060$, $p=0.255$. First, Motivation to Learn negatively and insignificantly correlated with Speaking Skill Problems of Grade 11 and 12 Senior High School Students, $r=-0.063$, $p=0.230$. Second, Listening Skill Problems of Grade 11 and 12 Senior High School Students were negatively and insignificantly correlated with Motivation to Learn, $r=-0.090$, $p=0.087$. Third, Reading Skill Problems of Grade 11 and 12 Senior High School Students were negatively and insignificantly correlated with Motivation to Learn, $r=-0.003$, $p=0.951$. Finally, Motivation to Learn negatively and insignificantly correlated with Writing Skill Problems of Grade 11 and 12 Senior High School Students, $r=-0.045$, $p=0.396$.

Self-Determination Theory (SDT) by Ryan and Deci states that intrinsic motivation increases engagement, satisfaction, and performance. However, this result suggests that motivation to learn does not affect language learning problems. Other motivators like self-efficacy, task value, and interest may explain this finding. The result found no significant correlation between motivation and language learning problems, suggesting that extrinsic motivation or amotivation may be more important.

Rewards and punishments drive extrinsic motivation (Borah [42]). Amotivation is a lack of motivation or hopelessness about success (Tao et al. [43]). Chemsí et al. [44] state that the

theory also recognizes the influence of extrinsic motivation and amotivation, which are not related to autonomous and self-determined behavior, on behavior and performance. This study found no significant correlation, suggesting that extrinsic motivation or amotivation may affect language learning problems more. This relationship may require further study.

Another theory, Bandura's Social Cognitive Theory (SCT) from Schunk et al. [45], may support this result. SCT states that personal, behavioral, and environmental factors affect behavior. Personal factors include students' self-efficacy, while behavioral factors include their study habits and teacher feedback. Family and peer support are environmental factors. Thus, language learning problems may be caused by more than just motivation. Other personal, behavioral, and environmental factors may affect students' language learning outcomes [46-50].

3.6 Correlation between Motivation to Learn and Student Engagement

The Pearson correlation test showed significant bivariate and overall correlations between Motivation to Learn and Student Engagement, the mediating and dependent variables. Student Engagement positively correlated with Grade 11 and 12 Senior High School Students' Motivation to Learn, $r=0.579$, $p<0.001$ [51-53]. First, Affective Student Engagement positively and significantly correlated with the Motivation to Learn of Grade 11 and 12 Senior High School Students, $r=0.443$, $p<0.001$. Second, Behavioral Student Engagement positively and significantly correlated with Grade 11 and 12 Senior High School Students' Motivation to

Learn, $r=0.530$, $p<0.001$. Finally, Cognitive Student Engagement positively and significantly correlated with Grade 11 and 12 Senior High School Students' Motivation to Learn, $r=0.450$, $p<0.001$.

Goal setting increases motivation and performance, according to Locke and Latham's [6] Goal-Setting Theory. This study found a positive correlation between Student Engagement and Motivation to Learn. Lee, Ho, and Chen [21] proposed that the positive relationship between specific types of student engagement (affective, behavioral, and cognitive) and Motivation to Learn provides further evidence that engaging students in different ways can motivate them. This is related to the work of Locke and Latham [6] where engaged students set specific, challenging, and attainable goals, which can boost motivation and performance. The Goal-Setting Theory suggests that student engagement can boost motivation and learning.

3.7 Mediation Analysis

Second, as presented in Table 5, when conducting a simple regression Motivation to Learn mediates the relationship between Language Learning Problems and Student Engagement. Mediation Analysis and

Path Analysis (Jenatabadi) revealed the following:

First, as shown in Table 5, a simple regression analysis of Grade 11 and 12 Senior High School Students' Language Learning Problems predicts Student Engagement for Path C (Standard C) alone ($\beta=.21$, $p<.05$). Second, as shown in Table 6, when conducting a simple regression analysis to determine the direct relationship between Language Learning Problems and Motivation to Learn to test for Path A, Grade 11 and 12 Senior High School Students do not significantly affect their Motivation to Learn ($\beta=-.10$, $p=.25$). Third, as shown in Table 6, a multiple regression analysis shows that Grade 11 and 12 Senior High School Students' Motivation to Learn significantly affects their engagement in their classes ($\beta=.523$, $p<.001$). After Motivation to Learn has intervened, Language Learning Problems predict Student Engagement for Path C' (C Prime). ($\beta=.26$, $p<.005$) [54-58]

Traditional mediation data interpretation methods like Baron and Kenny, discussed in Warner (645-687) on testing if the predictor variable (X, Language Learning Problems) affects the mediator variable (M, Motivation to Learn), Since mediation only makes sense if X affects M, M is just a third variable that may or may not be associated with Y [59-62].

Table 4c. Significance on the Relationship between Motivation to Learn and Student Engagement

Motivation to Learn	Student Engagement			Overall
	Affective	Behavioral	Cognitive	
	.443**	.530**	.450**	.579**
	.000	.000	.000	.000

Table 5. Simple regression for path C (Standard C)

Standard C (Before Mediation)	Estimate (β)	S.E.	C.R.	P	Label
STE <-- LLP	.206	.080	2.580	.010	Sig.

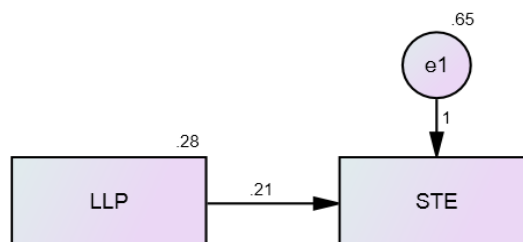

Fig. 2. Path Diagram for the Direct Relationship between Language Learning Problems and Student Engagement before mediation

Modern methods, like the one proposed by McKinnon et al. on Newsom (1)'s Path Analysis for Structural Equation Modelling, show that Step 4 is taken if Steps 1 through 3 have significant relationships. The Step 4 model supports partial mediation if M (Path b) remains significant after controlling for X. Since X is still significant (i.e., both X and M significantly predict Y), this study supports partial mediation [63-66].

Overall, the study's result points out that: First, the higher engagement students have with their English classes, the fewer problems in Language Learning the students will experience. This implies that engaged students are motivated to learn and are invested in their education, which can lead to a more positive and successful learning experience.

Mercer [17] stated that engaged students are more likely to learn and practice the language, which can lead to a greater sense of accomplishment and confidence in using the language. Second, English learning is easier for motivated students. Motivated students are more likely to work hard to learn the language, which can lead to a better learning experience.

Alawamleh, Al-Twait, and Al-Saht believed that motivated students are more likely to study, practice, and use the language, which can boost their confidence and sense of accomplishment [20]. Finally, class engagement rises with students' language motivation.

Thus, motivation is crucial to language learning, and motivated students are more engaged in class and the learning process. This idea is in line with Nagle [27] who suggested that this could lead to a more well-rounded understanding of the language and make learning more enjoyable, which would encourage students to participate in class discussions and activities.

Gardner's Socio-educational Model [2] supports the conclusions. Engagement in class and motivation to learn the language are positively correlated with fewer language learning problems. Socio-cultural and motivational factors contribute to language learning. Thus, the study supports Gardner's Socio-educational Model's emphasis on language learning motivation and attitudes.

Table 6. Regression Weights for the Paths A, B, and C' (C Prime)

Path Analysis of Three Variables			Estimate (β)	S.E.	C.R.	P	Label
MTL	<---	LLP (Path A)	-.103	.091	-1.142	.253	Not Sig.
STE	<---	LLP (Path C')	.260	.064	4.038	<.005	Sig.
STE	<---	MTL (Path B)	.523	.038	13.940	<.005	Sig.

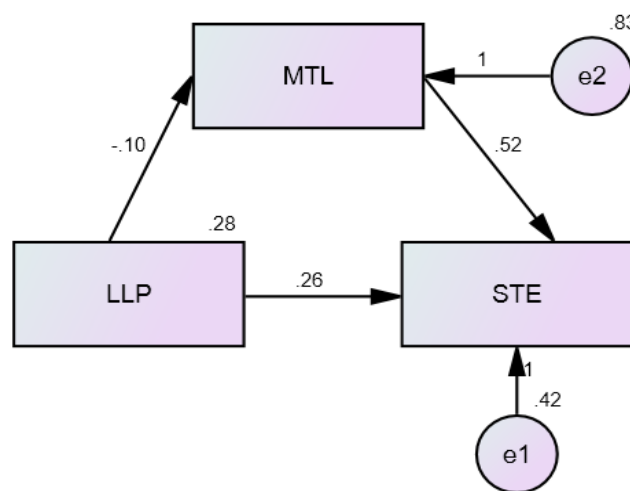

Fig. 3. Path Diagram for the Direct Relationship between LLP & MTL and MTL and STE, and Indirect Relationship between LLP & STE after mediation

4. CONCLUSION AND RECOMMENDATIONS

This part of the paper will specifically present the encapsulation of the results and findings of the study, as well as the recommendations that are based on the findings and results of the study.

Grade 11 and Grade 12 language learning difficulty levels are low, which matches markers of speaking, reading, writing, and listening skills. Their issues are not evident, indicating great language learning. Despite the "low" result, teachers should still address students' issues, especially in Writing, which has the highest Mean Value of the four indicators. Students can practice writing through creative writing, research papers, and presentations. External stakeholders should encourage community members to mentor or volunteer with writing-challenged students. Parents can communicate with teachers about writing issues. Addressing writing issues may improve children' linguistic and academic skills over time. Finally, academic institutions could fund writing help programs or institutes. These centers can help kids with writing through tutoring, assistance, and resources.

Respondents exhibit moderate affective, cognitive, and behavioral student engagement. Each indicator suggests moderate student participation. Clear objectives, procedures, and timely feedback can help teachers improve behavioral involvement. Encourage active classroom participation and student ownership of learning. External stakeholders could help schools arrange community events and student involvement activities. Allow students to exhibit their talents, serve the community, and apply their studies. Parent-teacher meetings and school events can promote student participation. Researchers may study student engagement interventions and support systems, evaluate pedagogical methods, technology integration, and student-centered learning. Teachers could receive professional development in student involvement from academic institutions. Provide training on classroom management, instructional tactics, and good learning environments.

Grade 11-12 students have moderate learning motivation. Teachers can motivate students by offering a choice of learning options and opportunity to explore their interests and customise their learning experience. External stakeholders could inspire kids by inviting

community people to mentor or speak. Parents may create a learning-friendly home. Regularly update parents on their child's progress and offer home motivating resources. Future scholars could study ways to motivate and engage students. Finally, student-centered and inquiry-based teaching can foster intrinsic motivation and autonomy in academic institutions.

Language learning issues affect Grade 11 and Grade 12 student involvement. Teachers could use instructional tactics to help children with writing, speaking, reading, and listening. External stakeholders should work with community resources to help pupils study languages outside of school. Parents can encourage teachers and parents to talk about language learning issues and student participation. Future studies should examine language learning techniques that reduce student disengagement. Finally, academic institutions might provide personalized support for language learners to meet their requirements and maximize engagement.

Students are motivated to learn regardless of linguistic issues. Language Learning Problem does not influence Motivation to Learn. Teachers can use differentiated instruction to help language learners and motivate them. External stakeholders could work with schools to arrange inspiring language learning workshops or events. Parent seminars or information sessions could teach parents how to motivate their children to learn, regardless of language learning issues. Qualitative methods could help academics understand students' intrinsic motivation and resilience in language acquisition. Finally, academic institutions could collaborate with counselors, learning specialists, and other professionals to address language learning and motivation challenges.

Learning motivation affects student engagement. To keep students engaged, teachers could monitor and alter lessons based on student motivation. External stakeholders could partner with schools to offer motivational events or workshops to keep kids motivated in learning. Parents may motivate pupils at home by fostering a positive learning atmosphere. Future studies could examine how intrinsic and extrinsic motivation affects student involvement. Finally, schools might employ recognition systems, student-led activities, and community partnerships to create a good and encouraging learning environment.

Motivation to learn partially affects Language Learning Problems and Student Engagement. Students can build intrinsic drive for studying in a positive and motivating classroom. Use engaging methods, meaningful activities, and student liberty and choice. External stakeholders could engage with schools to conduct motivational events or seminars that promote education and give role models and mentors to inspire children. Parents may create a positive home environment that values education and encourages students to learn. Discuss language learning and motivational difficulties with teachers. Motivation affects language learning challenges and student involvement. Explore potential moderators or mediators to better understand this relationship. Finally, academic institutions might deploy full language learning and motivation support systems. Language support, counseling, and teacher-counselor-support staff collaboration are examples.

CONSENT

As per international standard, parental written consent has been collected and preserved by the author(s).

ETHICAL APPROVAL

The study acquired the Ethics Review Certification from the University of Mindanao Ethics Review Committee.

COMPETING INTERESTS

Authors have declared that no competing interests exist.

REFERENCES

1. Zólyomi A. Exploring Hungarian secondary school English teachers' beliefs about differentiated instruction. *Lang Teach Res.* 2022;13621688221114780.
2. Gardner RC. The socio-educational model of second language acquisition. *The Palgrave handbook of motivation for language learning.* 2019;21-37.
3. Wallace MP, In EIL, Leong L. Exploring language learning motivation among primary EFL learners. *J Lang Teach Res.* 2020;11(2):221-30.
4. Saeki E. Student engagement and motivation: an evaluation of their relations to social- emotional and behavioral functioning. Ann Arbor: University of California, Santa Barbara. ProQuest; 2012. Available: <https://www.proquest.com/dissertations-theses/student-engagement-motivation-evaluation-their/docview/1237894839/se-2?accountid=31259>
5. She L, Ma L, Jan A, Sharif Nia H, Rahmatpour P. Online learning satisfaction during COVID-19 pandemic among Chinese university students: The serial mediation model. *Front Psychol.* 2021;12:743936.
6. Locke EA, Latham GP. The development of goal setting theory: A half century retrospective. *Motiv Sci.* 2019;5(2):93-105.
7. Getie AS. Factors affecting the attitudes of students towards learning English as a foreign language. *Cogent Educ.* 2020;7(1):1738184.
8. Daily SM, Mann MJ, Kristjansson AL, Smith ML, Zullig KJ. School climate and academic achievement in middle and high school students. *J Sch Health.* 2019;89(3):173-80.
9. Wang Y. Probing into the boredom of online instruction among Chinese English language teachers during the Covid-19 pandemic. *Curr Psychol.* 2023:1-15.
10. Amirian SMR, Komesh N. A study on the relationship between EFL learners' nationality and language learning motivation. *Int J Appl Linguist Engl Lit.* 2018;7(2):26-32.
11. Tolman EC. Behavior and psychological man: essays in motivation and learning. University of California Press; 2022.
12. Dincer A, Yeşilyurt S, Noels KA, Vargas Lascano DI. Self-determination and classroom engagement of EFL learners: A mixed-methods study of the self-system model of motivational development. *Sage Open.* 2019;2158244019853913;9(2):9.2.
13. Asenahabi BM. Basics of research design: A guide to selecting appropriate research design. *Int J Contemp Appl Res.* 2019;6(5):76-89.
14. Dizon SG, Fernandez PMQ, Dalangin HRS, Mungcal KS, Tolentino JC, Valenzuela LR. Sustaining pre-service teachers' virtual engagement in a health education course through interactive buzz sessions. *IJMABER.* 2022;3(8):1526-47.
15. Zhou S, Thompson G. Exploring role of English proficiency, self-efficacy, and motivation in listening for learners transitioning to an English-medium

- transnational university in China. *System*. 2023;113:102998.
16. Fernández-Dobao A. Collaborative writing in mixed classes: What do heritage and second language learners think? *Foreign Lang Ann*. 2020;53(1):48-68.
 17. Mao Z, Lee I. Researching L2 Student Engagement with Written Feedback: Insights from Sociocultural Theory. *TESOL Q*. 2022;56(2):788-98.
 18. Yusuf Q, Jusoh Z, Yusuf YQ. Cooperative learning strategies to enhance writing skills among second language learners. *Int J Instruction*. 2019;12(1):1399-412.
 19. Locke EA, Latham GP. The development of goal setting theory: a half century retrospective. *Motiv Sci*. 2019;5(2):93-105.
 20. Alawamleh M, Mohannad Al-Twait L, Raafat Al-Saht G. The effect of online learning on communication between instructors and students during Covid-19 pandemic. *Asian Educ Dev Stud*. 2020;11(2):380-400.
 21. Kareem J, Thomas RS, Nandini VS. A conceptual model of teaching efficacy and beliefs, teaching outcome expectancy, student technology use, student engagement, and 21st-century learning attitudes: a STEM education study. *Interdiscip J Environ Sci Educ*. 2022;18(4):e2282.
 22. Chi C, Chen HH, Tseng W, Liu Y. Efficacy of different presentation modes for L2 video comprehension: Full versus partial display of verbal and nonverbal input. *ReCALL*. 2023;35(1):105-21.
 23. Alyousif R, Alsuhaibani Z. English language learning demotivating factors for Saudi high school EFL students. *Engl Lang Teach*. 2021;14(8):29-39.
 24. Evans M, Tragant E. Demotivation and dropout in adult EFL learners. *TESL E J*. 2020;23(4):n4.
 25. Tran LH, Moskovsky C. Students as the source of demotivation for teachers: A case study of Vietnamese university EFL teachers. *Soc Psychol Educ*. 2022;25(6):1527-44.
 26. Eviana Putri AE, Sumarno S, Hardiyanto A. Motivation in learning English employed by the low-medium-high ability students of the first-year English education study program at universitas muhammadiyah Kotabumi academic year 2019/2020. *Griya Cendikia*. 2021;6(2):155-68.
 27. Nagle C. Using Expectancy Value Theory to understand motivation, persistence, and achievement in university-level foreign language learning. *Foreign Lang Ann*. 2021;54(4):1238-56.
 28. Alamer A, Al Khateeb A. Effects of using the WhatsApp application on language learners motivation: a controlled investigation using structural equation modelling. *Comput Assist Lang Learn*. 2023;36(1-2):149-75.
 29. Lestari M, Wahyudin AY. Language learning strategies of undergraduate EFL students. *J Engl Lang Teach Learn*. 2020;1(1):25-30.
 30. Philippakos ZoiA. Traga. Developing strategic learners: Supporting self-efficacy through goal setting and reflection." *Lang Literacy Spec*. 2020;30(1):n1.
 31. Anwar F. Activity-based teaching, student motivation and academic achievement. *J Educ Educ Dev*. 2019;6(1):154-70.
 32. Lambert C, Zhang G. Engagement in the use of English and Chinese as foreign languages: the role of learner-generated content in instructional task design. *Mod Lang J*. 2019;103(2):391-411.
 33. Ryan RM, Deci EL. Intrinsic and extrinsic motivation from a self-determination theory perspective: Definitions, theory, practices, and future directions. *Contemp Educ Psychol*. 2020;61:101860.
 34. Pawapatcharandom R. An investigation of Thai students' English language problems and their learning strategies in the international program at Mahidol University. *King Mongkut's Inst Technol*; 2007.
 35. Patrick R. Comprehensible Input and Krashen's theory. *J Classics Teach*. 2019;20(39):37-44.
 36. Naibert N, Vaughan EB, Brevick K, Barbera J. Exploring student perceptions of behavioral, cognitive, and emotional engagement at the activity level in general chemistry. *J Chem Educ*. 2022;99(3):1358-67.
 37. Sari FM. Exploring English learners' engagement and their roles in the online language course. *J Engl Lang Teach Linguist*. 2020;5(3):349-61.
 38. Bashori M, van Hout R, Strik H, Cucchiarini C. Web-based language learning and speaking anxiety. *Comput Assist Lang Learn*. 2022;35(5-6):1058-89.
 39. Ulfa M, Bania AS. EFL student's motivation in learning English in Langsa, Aceh.

- Stud Engl Lang Educ. 2019;6(1): 163-70.
40. Alamer A, Almulhim F. The interrelation between language anxiety and self-determined motivation; A mixed methods approach. *Front Educ. Frontiers Media SA.* 2021;6.
 41. Feng L, Papi M. Persistence in language learning: the role of grit and future self-guides. *Learn Individ Differ.* 2020;81: 101904.
 42. Borah M. Motivation in learning. *Crit Rev.* 2021;8(2):550-2.
 43. Tao K, Liu W, Xiong S, Ken L, Zeng N, Peng Q, et al. Associations between self-determined motivation, accelerometer-determined physical activity, and quality of life in Chinese college students. *Int J Environ Res Public Health.* 2019;16(16): 2941.
 44. Chemsı G, Sadiq M, Radid M, Talbi M. Study of the self-determined motivation among students in the context of online pedagogical activities. *Int J Emerg Technol Learn.* 2020;15(5):17-29.
 45. Schunk DH, DiBenedetto MK. 'Social cognitive theory, self-efficacy, and students with disabilities: Implications for students with learning disabilities, reading disabilities, and attention-deficit/hyperactivity disorder.' *Handbook of educational psychology and students with special needs.* Routledge. 2020; 243-61.
 46. Abe KJ, et al. 'The Language Learning Difficulties and Coping Mechanisms Among UM Foreign Students.' *University of Mindanao. UM College of Teacher Education.* 2017;1-50.
 47. Atmojo AEP, Nugroho A. EFL classes must go online! Teaching activities and challenges during COVID-19 pandemic in Indonesia. *Regist J.* 2020;13(1):49-76.
 48. Bong M, Cho C, Ahn HS, Kim HJ. Comparison of self-beliefs for predicting student motivation and achievement. *J Educ Res.* 2012;105(5):336-52.
 49. Chen W, Yu S. A longitudinal case study of changes in students' attitudes, participation, and learning in collaborative writing. *System.* 2019;82:83-96.
 50. Esra MEŞE, Sevilen Ç. Factors influencing EFL students' motivation in online learning: A qualitative case study. *J Educ Technol Online Learn.* 2021;4(1):11-22.
 51. Fitriyani S, Andriyanti E. Teacher and students' politeness strategies in EFL classroom interactions. *Indonesian J Engl Lang Teach Appl Linguist.* 2020;4(2):259-73.
 52. Gopinathan S, Kaur AH, Veeraya S, Raman M. The role of digital collaboration in student engagement towards enhancing student participation during COVID-19. *Sustainability.* 2022;14(11):6844.
 53. Lee T-Y, Ho Y-C, Chen C-H. Integrating intercultural communicative competence into an online EFL classroom: an empirical study of a secondary school in Thailand. *Asian Pac J Second Foreign Lang Educ.* 2023;8(1):1-25.
 54. Lou NM, Noels KA. Promoting growth in foreign and second language education: A research agenda for mindsets in language learning and teaching. *System.* 2019;86:102126.
 55. Mercer S. Language learner engagement: Setting the scene. In: *Second handbook of English language teaching.* 2019; 643-60.
 56. Nartiningrum N, Nugroho A. Online learning amidst global pandemic: EFL students' challenges, suggestions, and needed materials. *Engl Franca Acad J Engl Lang Educ.* 2020;4(2):115-40.
 57. Ng CH. Communicative Language Teaching (CLT) through synchronous online teaching in English language preservice teacher education. *Int J TESOL Stud.* 2020;2(2):62-73.
 58. Ryan RM, Donald JN, Bradshaw EL. Mindfulness and motivation: A process view using self-determination theory. *Curr Dir Psychol Sci.* 2021;30(4): 300-6.
 59. Sari SN, Aminatun Dyah. Students. Perception on the use of English movies to improve vocabulary mastery *Journal of English Language Teaching and Learning.* 2021;2(1):16-22.
 60. Simamora RM. The Challenges of online learning during the COVID-19 pandemic: An essay analysis of performing arts education students. *Stud Learn Teach.* 2020;1(2):86-103.
 61. Torres J, Alieto E. English learning motivation and self-efficacy of Filipino senior high school students. *Asian EFL J.* 2019;22(1):51-72.
 62. Vallerand RJ. Reflections on the legacy of self-determination theory. *Motiv Sci.* 2021;7(2):115-6.
 63. Xu B, Chen N-S, Chen G. Effects of teacher role on student engagement

- in WeChat-Based online discussion learning. *Comput Educ.* 2020;157: 103956.
64. Zaidi R. Dual-language books: Enhancing engagement and language awareness. *J Literacy Res.* 2020;52(3):269-92.
65. Zhou J, Yu H. Contribution of social support to home-quarantined Chinese college students' well-being during the COVID-19 pandemic: The mediating role of online learning self-efficacy and moderating role of anxiety. *Soc Psychol Educ.* 2021;24(6): 1643-62.
66. Zou D. Gamified flipped EFL classroom for primary education: student and teacher perceptions. *J Comput Educ.* 2020;7(2): 213-28.

© 2023 Arcipe and Balones; This is an Open Access article distributed under the terms of the Creative Commons Attribution License (<http://creativecommons.org/licenses/by/4.0>), which permits unrestricted use, distribution, and reproduction in any medium, provided the original work is properly cited.

Peer-review history:

The peer review history for this paper can be accessed here:
<https://www.sdiarticle5.com/review-history/101606>